

THE **ONE** FOR YOU

MOTEL ONE
Tegernseer Landstrasse 165
D-81539 München
Tel.: +49/89/66 50 25-832
Fax: +49/89/66 50 25-50
development@motel-one.com

[WWW.MOTEL-ONE.COM](http://www.motel-one.com)

Version 02/2017



LIKE THE PRICE.
LOVE THE DESIGN.

DISCOVER **MOTEL ONE**



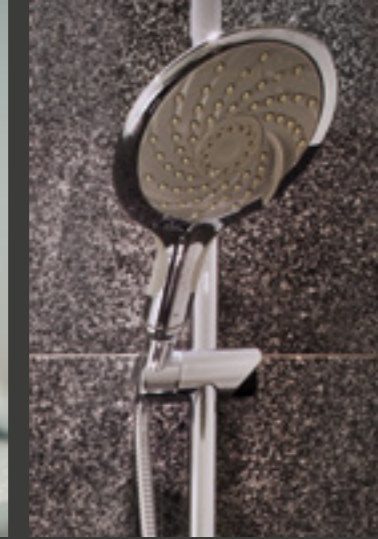
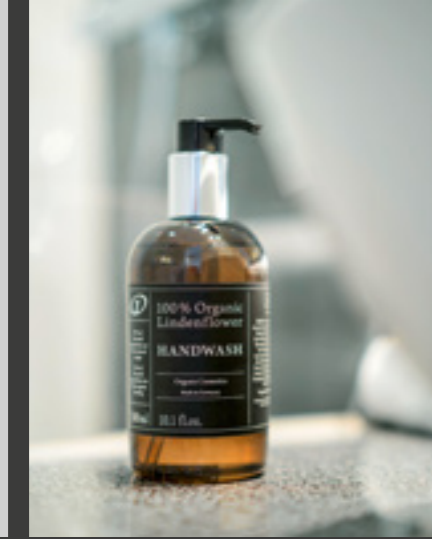

AFFORDABLE LUXURY

Our guests enjoy finest Egyptian cotton sheets and top of the range box-spring beds, experiencing a truly exceptional environment of designer furniture and recognised brands at a fair price point – our idea of affordable luxury – starting at € 59.

HIGH QUALITY MATERIALS

- Box-spring bed
- Egyptian cotton
- Dark granite
- Organic amenities
- Fluffy 600g towels

RENOWNED BRANDS:

- Artemide lights
- LG 43" Flat-screen TV
- Dornbracht bath fittings
- Hansgrohe raindance shower
- Freifrau relax chair
- B&B Italia desk



CHOCOLATE IN ZURICH



BICYCLES IN AMSTERDAM



BRITPOP IN MANCHESTER

NEIGHBOURHOOD

We like each hotel to be different. Our hotels each have a unique design and feature different furniture. We care about the local environment and work with local artists and craftsmen to engage with the "neighbourhood story".



LAPTOP AND LEDERHOSE IN MUNICH



MOTEL ONE PRAGUE

LIFESTYLE

Designer lounges, free wifi and communal work spaces create an intimate and functional environment that caters for the changing tastes of modern travellers. Our dedication to the highest quality and service is visible in our stylish bars, open to everybody around the clock. Guests can choose from a wide range of high-quality spirits, regional selections of wine and beer and other refreshing beverages.



MOTEL ONE
WIEN-HAUPTBAHNHOF



MOTEL ONE
BERLIN-TIERGARTEN



MOTEL ONE BERLIN-UPPER WEST

FACTS & FIGURES

At the end of Q2/2017 Motel One had 57 hotels with more than 15,400 bedrooms of which 16 hotels with 4,600 bedrooms are located outside of Germany. Motel One has successfully established its brand in major European cities including London, Berlin, Amsterdam, Prague, Vienna and Zurich. Over the next two years Motel One will open hotels in other top destinations including Paris, Barcelona and Warsaw.

A secured pipeline of 30 hotels with more than 9,900 bedrooms will see Motel One operating 87 hotels with 25,300 bedrooms in 11 countries by 2020.

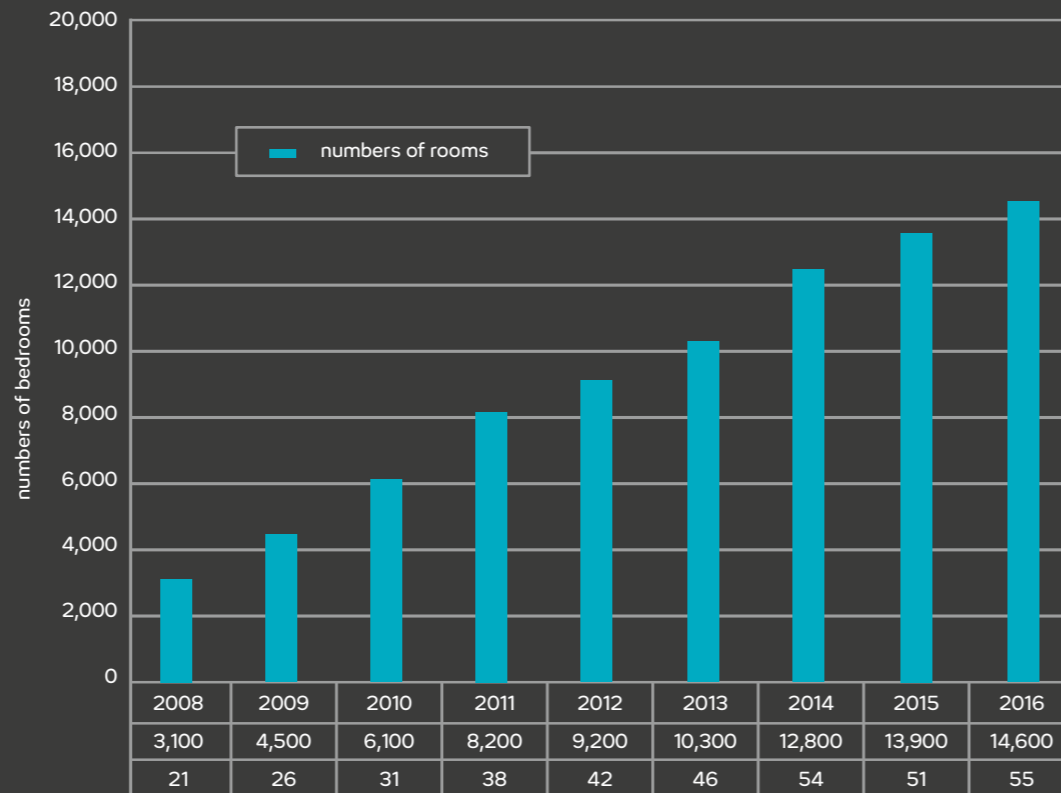

CURRENT LOCATIONS

STATUS Q2 2017

TOTAL 57 HOTELS / 15,400 BEDROOMS
INTERNATIONALLY 16 HOTELS / 4,600 BEDROOMS

SECURED PIPELINE

TOTAL 30 HOTELS / 9,900 BEDROOMS
INTERNATIONALLY 10 HOTELS / 2,800 BEDROOMS



QUICK CHECK LOCATION

- Major European cities
- City centre
- Excellent public transport



QUICK CHECK SITE

SITE:

- New build
- Conversions
- Single or mixed-use developments

FORM OF CONTRACT:

- Purchase
- Lease
- Joint venture

SPACE REQUIREMENTS:

- Gross floor area 27-30 m² per bedroom (including all front of house and back of house areas)
- Net internal area 16 m² per bedroom
- Minimum GFA 3,000 m²
- Motel One specification available on request

STANDARD ROOM LAYOUT:

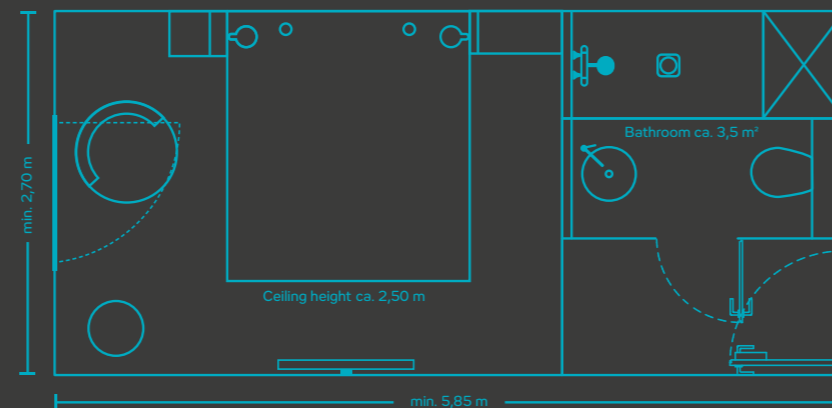

EUROPEAN EXPANSION

In its international expansion Motel One focuses on major European cities.

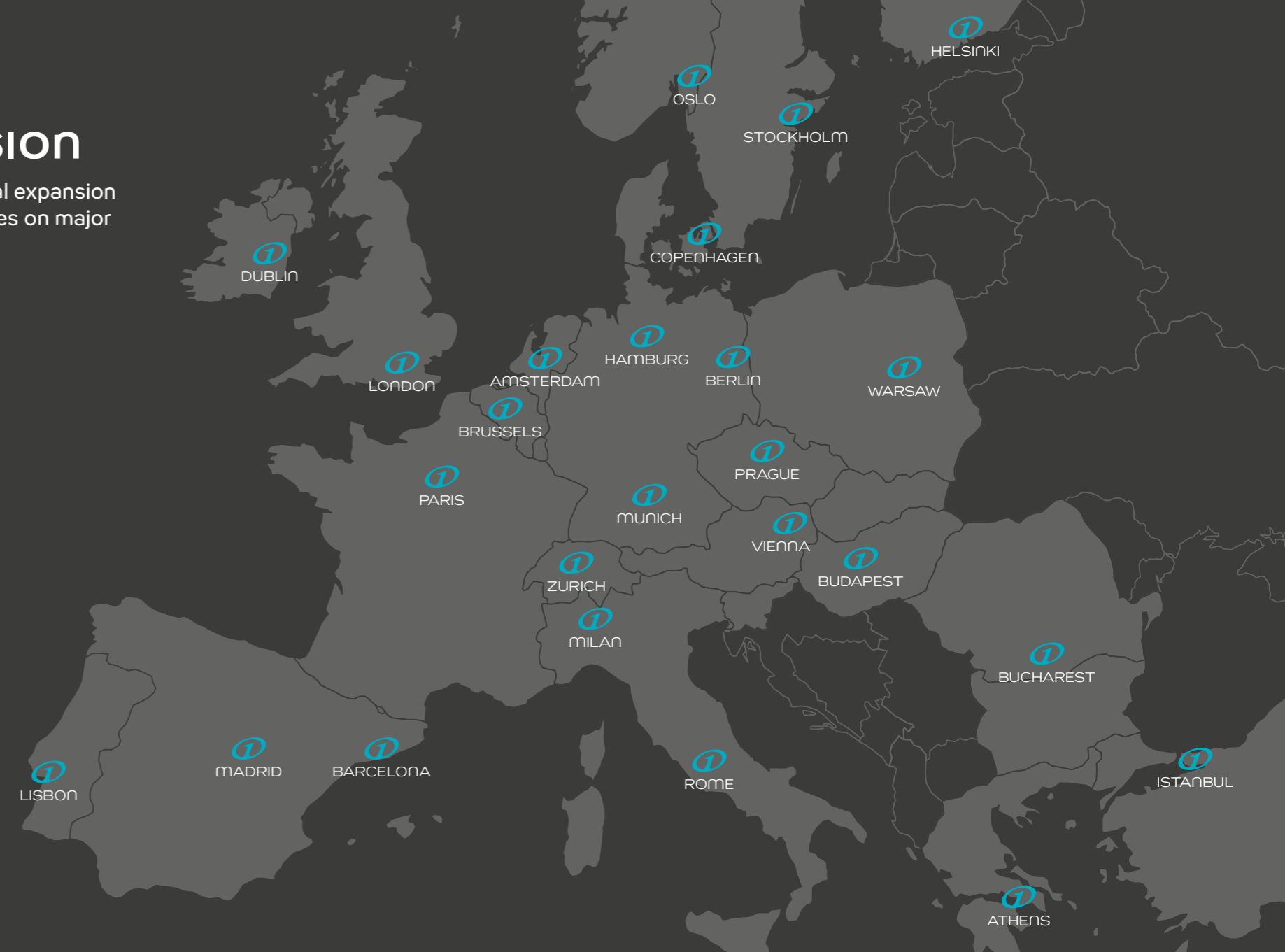

RECENT SELECTED AWARDS & RATINGS

- AWARDS** 2017: "German Brand Award" in the category
Brand Innovation of the Year & Industry Excellence in Branding 2017
"City Budget Hotel of the Year" at the Scottish Hospitality Awards 2017
"German Service Prize" in the Tourism category, awarded by German Institute for Service Quality
- 2016: "Best Employer in the Hospitality Industry Award" received from Focus Magazine & kununu for the second time
"Platow Real Estate Award" by the financial service "Platow Brief"
"Lifetime achievement award" for Dieter Müller awarded by International Hotel Investment Forum
"Entrepreneur of the year" for Dieter Müller & Ursula Schelle-Müller awarded by Ernst & Young
- RATINGS** 2016: AAA rated in the Investment Ranking by Treugast Solutions Group for the eighth time since 2008
"Bundesbank Rating" equivalent to S&P or FITCH Investment Grade A

INVESTMENT PARTNERS



MOTEL ONE GROUP FINANCIAL SUMMARY

KEY PERFORMANCE METRICS	2010	2011	2012	2013	2014	2014	2016
No. Hotels	31	38	42	46	54	51	55
No. Rooms	6,118	8,193	9,221	10,293	12,822	13,887	14,583
- Owned rooms	2,394	3,222	3,757	3,310	3,563	2,493	2,984
- Owned rooms in %	39%	39%	41%	32%	28%	18%	20%
Occupancy	71%	70%	73%	75%	75%	75%	77%
Rev per Room sold	€ 69	€ 73	€ 76	€ 78	€ 81	€ 88	€ 89
P&L STATEMENT (TEUR)							
Revenue	90,905	134,763	174,561	205,460	256,358	321,697	357,411
EBITDA	34,180	44,210	62,217	72,553	81,219	96,617	111,036
EBIT	21,837	27,756	39,696	50,353	54,290	69,880	79,952
Operating profit	18,750	23,365	33,913	43,544	50,490	63,743	72,213
Capital gain on hotel properties	0	0	0	25,988	20,458	35,712	56,265
EBT	18,750	23,365	33,913	69,532	70,948	99,455	128,478
Tax	-6,472	-8,392	-13,016	-18,748	-21,570	-22,004	-36,865
Net Profit	12,278	14,973	20,897	50,784	49,378	77,451	91,613
BALANCE SHEET (TEUR)							
Fixed Assets	221,288	267,951	314,684	346,415	428,703	436,443	535,590
Net Working Capital	18,240	26,273	32,180	36,626	55,881	55,595	-14,339
Net Debt	67,228	91,120	111,270	82,739	94,909	48,864	153,063
Equity	135,820	150,558	171,234	227,050	277,913	331,984	396,866
Net Debt / EBITDA	2.0	2.1	1.8	1.1	1.2	0.5	1.4



MOTEL ONE
ENVIRONMENT

A number of our hotels are certified by leading assessment methods such as BREEAM, LEED and DGNB.

MOTEL ONE
LONDON-TOWER HILL

BREEAM – Excellent

291 Rooms

New construction in the heart of London’s financial centre in the City of London, just a half mile from Tower Bridge and the Tower of London.

MOTEL ONE
AMSTERDAM

BREEAM – Excellent

The first hotel in the Netherlands to be awarded the BREEAM – Excellent certificate (Source: Dutch Green Building Council)

320 Rooms

New construction, located opposite the Amsterdam RAI Exhibition and Convention Centre.





MOTEL ONE
WIEN-STAATSOPER

400 Rooms

Conversion of a listed property from the turn of the century (19th/20th century), situated next to the Opera House in the 1st district of Vienna.

MOTEL ONE
EDINBURGH-ROYAL

208 Rooms

Conversion of a historical building from the 16th and 18th century; part of Edinburgh's Old Town, a UNESCO world heritage site.





MOTEL ONE BERLIN-POTSDAMER PLATZ

239 Rooms

New construction – integrated in the Mall of Berlin, situated on Leipziger Platz and directly opposite the German Bundesrat (federal council) in the Mitte district.

MOTEL ONE BERLIN-UPPER WEST

DGNB certified

582 Rooms

New construction opposite the Kaiser Wilhelm Memorial Church in the heart of Berlin's City West; mixed-use project with Motel One as anchor tenant from the ground to the 17th floor and a roof terrace on the 10th floor.





MOTEL ONE ZURICH

394 Rooms

Conversion of the historic post building situated in Zurich's city centre close to the "Paradeplatz" and the famous "Bahnhofstrasse".

MOTEL ONE BARCELONA-CIUTADELLA

301 Rooms

opening 2017

New construction at the "Parc de la Ciutadella" within short walking distance to the old town of Barcelona.

